



3rd Quarter 2022



A WORLD

YOUTH NEWSLETTER MODEL A FORD CLUB OF AMERICA

THE SAWMILL AND THE RED AA TRUCK

BY SHERRY WINK

Dad Sitzman was whistling happily as he went about his chores early Saturday morning. He was looking forward to his planned trip to the next county to his friend Leland's sawmill. Dad Sitzman really enjoyed being around fresh-cut lumber, he said it smelled like nothing else in the world. Of course, he always enjoyed seeing Leland too!

Last fall, Dad Sitzman had helped Leland clear some timber on his farm, and in return, Leland had promised to set aside a few of the oak logs. Leland said when he had a little extra time, he would saw up some boards for Dad Sitzman.

There was always a need for boards at the Sitzman place. In fact, there was already a good stack of lumber in the lean-to behind the barn, stickered out to season for a few years before being used in Dad Sitzman's wood shop. ("Stickered out" means to stack fresh cut boards in layers with thin strips of wood separating them, so air can circulate and the wood can dry evenly.)



Dad Sitzman had oak and walnut, and even some maple and cherry wood tucked away, for when he made something special. And a lot of cedar, as he planned on making a cedar chest for each of the girls as they got older.

Dad Sitzman liked working with his hands, especially with wood. He loved the feel and smell of the wood as he shaped it into something both useful and beautiful. He had taught all the kids how to recognize the different woods by their grain and color, and often even by their smell!

One year, at Christmas, Mom Sitzman had been stunned by a brand new dining room table Dad Sitzman had worked on for months, without her ever catching him. She had complained for years about how small their old table was, especially when they had company. The new table was 14 feet long, out of maple, and glowed like it had a fire inside. Mom Sitzman almost didn't want to let the kids eat off it for fear of them scratching it, and Dad Sitzman just laughed and laughed, and told her that if they scratched it, he would be happy to fix it up just like new, but he had made it to be used, not just looked at.



There was a lot of furniture in the house built by Dad Sitzman, even all the beds the Sitzman kids slept in had been built one by one as the kids came along. Of course, when the twins showed up without advance warning, he had to quickly make a second bed!

(Continued on page 2)

<u>PAGE</u>	<u>TITLE</u>	<u>PAGE</u>	<u>TITLE</u>	<u>PAGE</u>	<u>TITLE</u>
1.	THE SAWMILL AND THE RED AA TRUCK	8.	A MODEL "A" ENDING TO A FAMILY VACATION!	12.	MODEL A YOUTH RESTORATION AWARD—2022
3.	KIDS & THEIR A'S	9.	JUBILEE CELEBRATION FOR A CASTLE!	13.	COLORING PAGE
4.	KIDS & THEIR A'S 2	9.	CAR-TOON	14.	RUMBLE SEAT
5.	MODEL A WATER PUMP	9.	ANSWER FOR SIX DIFFERENT THINGS	14.	QUIZ TIME
6.	SIX DIFFERENT THINGS	10.	THE FLYING QUAIL		
7.	1929 FORD MODEL A MOXIE HORSE-MOBILE	11.	UPDATES ON THE VALLEY FAMILY'S AA TRUCK!		

(Continued from page 1)

Earlier this week, Leland had called and let Dad know he had the boards ready to pick up and asked that some of the boys come along to load them. This was a job the older boys had all helped with in the past, and, like Dad Sitzman, were happy to assist with. After all, it wasn't something they did every day (so it wasn't boring) and besides, Leland had an ice chest at the mill that he kept stocked with ice-cold root beer that he generously shared with all helpers!



There was no lack of volunteers, but only the twins Richard and Robert got to go. There was limited room in the old AA truck Dad Sitzman was driving, to bring the boards back. Everyone felt better about being left behind when Dad Sitzman promised to bring them all a bottle of root beer if they help unload the truck when it got back home!

Dad Sitzman enjoyed driving the old truck. It had originally belonged to Grandma Roberts, but she had passed it on to them as she had gotten too old to need it. She said if she needed something that required the use of the AA, she would just call Dad Sitzman or one of the boys.

The truck was a faded red, and that too made Dad Sitzman smile. Because when Grandpa Roberts had brought the truck home brand new many, many years ago, it had been green. Grandma had been adamant she wanted a red truck, but the green one was all the Ford dealer had in stock, and Grandpa hadn't wanted to wait.

When Grandpa got up the next morning to check out the new truck, he walked into the barn just in time to see Grandma putting the final brush full of paint on the now RED truck. As Grandpa stood there with his jaw hitting the floor, Grandma walked out past him saying "I told you we were going to have a RED TRUCK!" And the truck stayed red for the rest of its life. Dad Sitzman always appreciated that story while counting his blessings that Mom Sitzman wasn't quite that opinionated!

With the twins loaded up in the AA, Dad Sitzman left immediately after breakfast, eager to get to the sawmill before it got too hot. He knew it would take a few hours to get there, load the wood, and get back. And of course, you had to calculate in a little visiting time as well! Leland and Dad Sitzman were old school classmates, and they always had stories to swap of the old days, along with current events. The twins didn't mind, they enjoyed listening to those stories of when their dad was their age. And it sounded like Dad Sitzman had been just as ornery as they were, which they found funny!

Once the AA pulled back into the Sitzman place, Dad Sitzman drove it behind the barn and directed the boys where to stack the new boards. He had them lay aside a few dozen boards that were drier than the newly cut boards. Leland had thrown them on when he saw the shape of the wood siding on the bed of the AA and teased Dad Sitzman about losing his load on the way back with all those worn-out planks on the sides.

Dad Sitzman had ruefully laughed and agreed that the job was a little overdue, and thanked Leland for the new boards to use as replacements. The boards would make a nice solid bed for the fall farming chores, and it was time to get it done.



And in truth, Dad Sitzman didn't really mind. It wasn't the calming work of making furniture, but it was still a chance to work with wood, smell the sawdust, and feel the accomplishment as he made something out of rough materials. But that was a job for another day, specifically tomorrow! And Dad Sitzman was whistling in happy anticipation as he walked up to the house to enjoy the hot supper Mom Sitzman had waiting on the maple table.



A-WORLD
YOUTH NEWSLETTER MODEL A FORD CLUB OF AMERICA

A-World is published by the Model A Ford Club of America for the benefit of youth and the promotion of the Model A hobby.



Editor: Sherry Winkinhofer
AWorldEditor@hotmail.com

© 2022 All Rights Reserved by

Model A Ford Club of America
250 South Cypress Street
La Habra CA 90631-5515

A-World is free, courtesy of MAFCA. As of May 2016, it became a web or email only publication. If you wish to have it emailed directly, please send your email address to AWorldEditor@hotmail.com

KIDS AND THEIR “A”s!



Jack and George Chuber live in Kansas and along with their dad Will, really enjoy Model A's! Also in this picture is their friend Kaitlyn, and Betsy, the little dog!



Garett, age 2, Everett age 4, Riley age 6, and Brinley age 4. They all live in Clinton, Illinois. Their great-great grand father bought this car new in 1930 and it has been in the family ever since!



Brooke Bristol, Age 11 Argyle, New York was the “official waver,” riding in her great-uncle Rob’s Model A in the Annual Thistle Day Celebration in Argyle. They also entered the car in the car show and won a second place award!



Otto Schulte, Age 5, is riding in the front seat of grandpa’s car. Rhaen Schulte, age 9, and Juniper Schulte, age 7 got to ride with Grandma Leslie in the rumble seat! Grandpa Otto is taking the picture. The family lives on Vancouver Island in British Columbia, Canada. “The Grands love riding in Henry!” says Grandpa!



Cadence Schaefer, age 5, lives in Creston, Iowa. Here, she is ready for her first day of pre-school in style!



Sydney Thompson, 8 years old, lives in Palmdale California and she is becoming quite an experienced Model A mechanic!

KIDS AND THEIR “A” PAGE 2



Sam Jandorf of Savannah Missouri visited the Jubilee Celebration at Krug Park in Saint Joseph Missouri in September. He spent quite a bit of time letting Rethan Edwards of Table Rock Nebraska tell him all about Model A's. Sam loves old cars and really enjoyed the opportunity to set behind the wheel, and of course, honk the ahooga horn!



*Above: Oliver working on changing the spark plugs.
Below: Oliver working on the car with the mentoring of Queen City Model A Club member Kalei.*



Walter working under the car and doing a great job!



Walter Berry, age 7, and Oliver Berry, age 8, live in Charlotte, North Carolina.

As you can see, both boys enjoy helping take care of the family's Model A. Their mom says the family won the jackpot when it comes to the local club, The Queen City Model A Club. She reports that the club welcomed the boys and the family with open arms, and seems to have enjoyed having the family, and especially the boys, visit the garage all summer long learning about working on their car.

Model A Water Pump

A water pump is a very important component in your car. Its job is to circulate water in your engine, to keep the motor from getting too hot. The water pump works as part of the cooling system which also includes the radiator, fan belt, and engine block. The water pump is connected to the fan blade, and they turn together with the fan belt which is connected to the crankshaft.

The water pump is a “centrifugal” pump. A centrifugal pump works like riding a playground merry-go-round. The faster you go in a circle, the more force you feel pushing you away from the center of it. The water pump is moving the water through in the same way. Inside the pump is an impeller, a part that is spinning rapidly. This throws the water to the edges of the pump, and causes a vacuum which pulls more water into the pump. The water pump helps keeps water circulating through the motor when paired up with the rest of the cooling system.

The entire cooling system is referred to as a “Thermo-siphon” cooling system. In simple terms, that means making use of the fact that water rises when hot and sinks when cool. So, the water pump pushes hot water (that has been heated by the motor) out of the engine block, into the radiator at the top hose. This forces the water already in the radiator to go down through the system as it cools off from the air flowing through the radiator. Then it goes through the lower hose up back into the engine block to do it all again. The water circulates through the system continuously, keeping the motor from overheating.

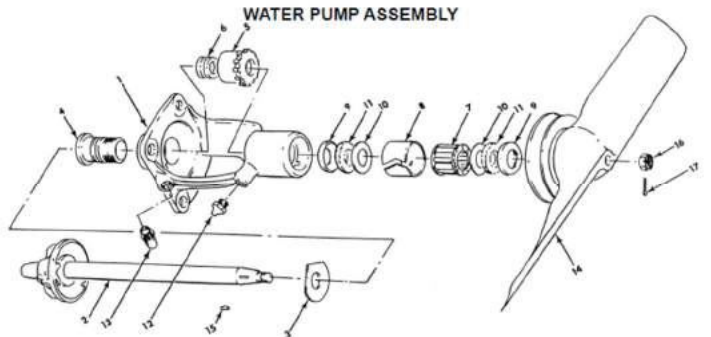
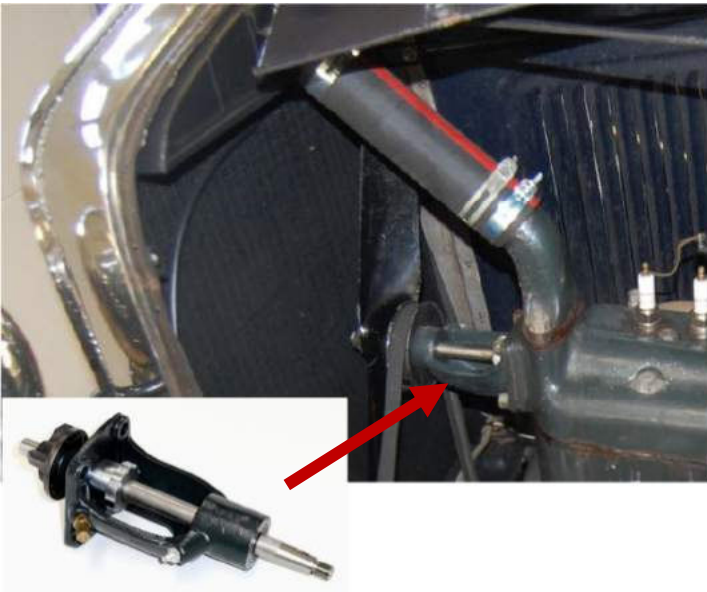
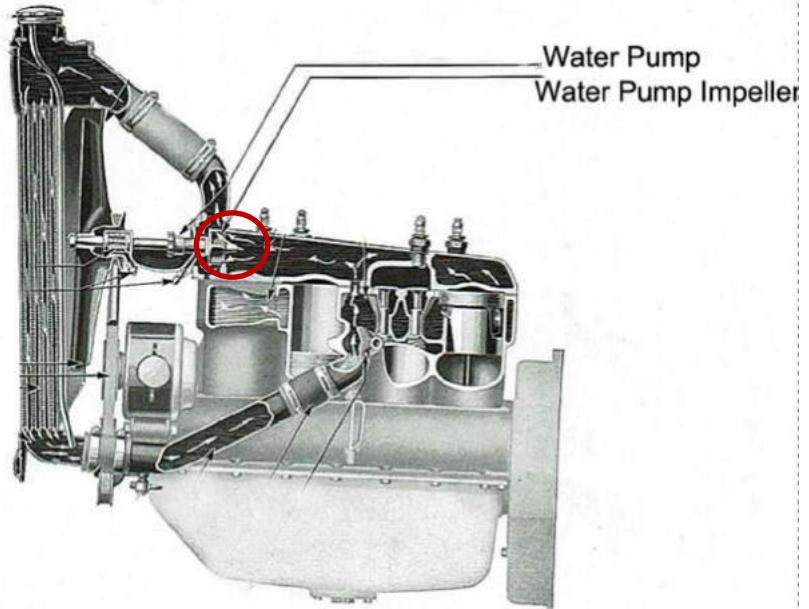

Index #	Part #	Description	No. Req.	Index #	Part #	Description	No. Req.
1	A-8501-PB	Pump Housing Only	1	6	A-8524-T	Teflon Packing	1
2	A-8510	Steel Shaft	1	7	A-8530	Roller Bearing	1
2	A-8510-SS	Stainless Shaft	1	8	A-8535	Roller Bearing Sleeve	1
3	A-8513-A	Steel Thrust Washer	1	9	A-8540-A	Bearing Cup Washer	2
3	A-8513-SS	Stainless Thrust Washer	1	10	A-8554	Flat Bearing Washer	2
4	A-8520	Rear Bushing Assembly	1	11	A-8542	Bearing Felt	2
4	A-8520-B	Rear Bushing Assembly (Brass)	1	12	A-353027	Grease Fitting	1
5	A-8523	Brass Pack Nut (28-29)	1	13	A-8501-FIT	Grease Fitting	1
5	A-8523-Z	Zinc Pack Nut (30-31)	1	14	A-8600-A	Fan	1
6	A-8524	Rope Style Packing	1	15,16,17	A-8510-MS	Fan Mounting Set	1

SIX THINGS ARE DIFFERENT!

The Model A's visited the 1928 Julian Gas Station Museum again this year. It still looks great, but the top picture looks like it's lost a few details compared to the bottom one. Can you find the differences?
The answers are on page 12 but don't peek too soon!



The 1929 Ford Model A Moxie Horse-Mobile

Moxie is a soda that is one of the first soft drinks available in the United States. First sold as a patent medicine in 1876, it is still a regional favorite in the New England states. As part of promotional program, the company commissioned a fleet of Moxie-Mobiles between WWI and WWII. They modified the cars by fitting them with a full-size model horse upon which the driver sat. The controls were modified to be usable by the driver as well. The first such modified version was in 1918. A different manufacturer was used for each car. About 2 dozen were maintained for used in parades and such. This one started as a 1929 Model A Ford, modified as a brand new car. It still has a four cylinder Model A engine.



A Model "A" Ending to a Family Vacation!

Juliet, Lucy, Lilly, Evie, and Peter Narworld, who range in age from 12 to 1, recently completed an eight week visit to the United States by visiting their grandparents in Colorado Springs, Colorado. The Narworlds, along with parents Josiah and Erica, live in Haineichen, Saxony, Germany.

Grandparents Andy and Carol Scheer spend much of the final few days giving rides around the neighborhood in their 1930 Town Sedan. It was a big hit, and the kids (and adults!) loved it. The younger girls got a kick from hearing the horn up close!



Jubilee Celebration for a Castle!



Krug park is a public park in Saint Joseph Missouri, and they recently held a 100th anniversary party for the building they call the "Castle." Not really a castle, this unique building was built to be a restaurant, but the depression came along before those plans could be finalized. Today it is just an interesting public space, at the end of a leisurely one-way loop drive through the park.

I took my car, The Old Lady, to help them celebrate the occasion, along with other Model A's and a few Model T's. My nephew Rethan went along as my co-pilot, and we drove ninety miles to enjoy the party!

This was Rethan's first attempt at an era outfit, and it was quite successful. A nice button-down shirt, with suspenders, black slacks rolled up a little to show off his argyle socks black boots, topped off with a newsboy cap. He looked great! He was surprised at how easy it was to do! And he already has plans to improve it for his next outing.

Rethan spent the day demonstrating a 1920s portable phonograph from atop the trunk on the back of The Old Lady. A little jazz music from Red Nichols (You Rascal You) was quite a crowd gatherer. In between that and showing off the motor to the inquiring public, he also took time to enjoy a cup of tea. This was from a British tea basket set that dates from around WWI but that was still a popular accessory in Model A days. And of course, he fielded all the questions about that as well. It was a busy afternoon, but he loved it all and said he is ready to do it all again when the chance arises!



Answers to Six Different Things

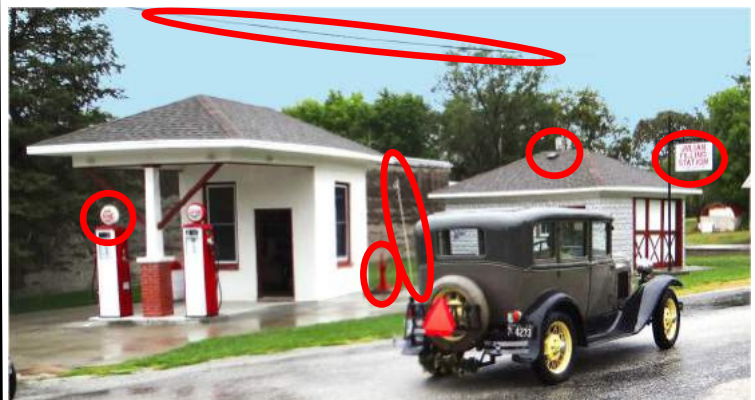
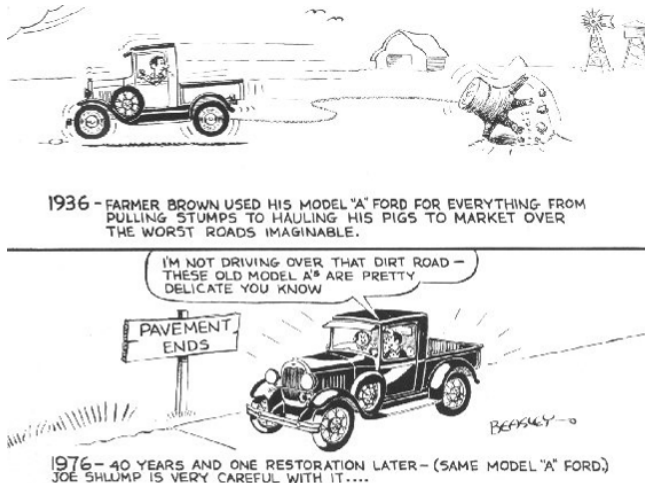

The Flying Quail

I'm sure you are all familiar with the hood ornament, or radiator cap, designed specifically for the Model A. Did you know Henry Ford did not manufacture them at his factories? He left that to a company called "The George Stant Company," which had quite a bit of experience building this type of item. Henry did stay involved with the process from the first to the last step.

At the time, these types of ornaments were called mascots, and their purpose was to project an image of speed or luxury or both. When it came time to decide on what to use as the Model A's mascot, Henry said he wanted one that illustrated the idea of a fast takeoff. The artist working with him on the design suggested a rabbit. Henry wanted something better, and then decided to use a quail, saying "a quail flushes just like a firecracker going off." Flushing is when the bird flies up from the bushes to get away from any perceived danger. Henry was an avid birdwatcher and did not hunt birds anymore, but he was familiar with the birds from his life on a farm.



The rough design was sent to the George Stant company to manufacture. They had to finalize the design into something that could be cast in metal. To get a more life-like design, they decided to bring in some live quail. It was quite a circus! The cage was put in the middle of the engineer's office, and surrounded by artists with easels, photographers, and mad engineers. The birds were not happy, screeching and flapping, and bouncing off the cage, with feathers and poop flying through the air! It only took three days for the company to decide they had enough info, and send the unhappy birds back to the farm.



As the design was being finalized, Henry Ford had to approve it each step of the way. It was said that a path was worn in the ground between the two companies before Henry gave his final approval! He wanted it just perfect for his new car. Edsel Ford, Henry's son, and the one that was in charge of most of the cosmetic elements of the car, wasn't that thrilled with the design, but Henry had the final say. It seems he was right, as the Flying Quail is still one of the most recognizable hood ornaments out there!

"Well, I'm glad he liked ONE of them!"

Original quail hood ornaments are very rare, and quite valuable today. They were made of pot metal which is not very durable, and many didn't survive over the years. There are many versions of reproductions to be found today, but most do not have quite the fine detail of the originals. They still look great sitting up front on the radiator of any Model A!

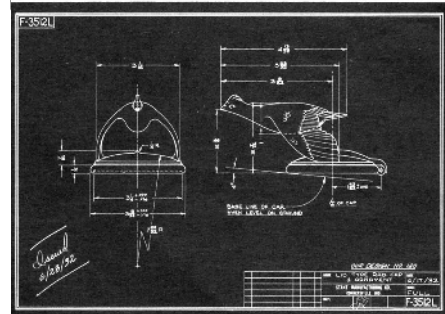
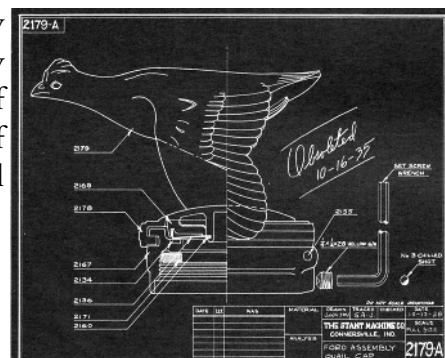

An original mascot



A modern reproduction

Updates on the Valley Family's AA Truck!

Remember the AA farm truck that Isabella Valley was pictured driving in the last issue? It is living the good life now! Once restored but then neglected for many years, it took Isabella's brother Lane to save it from rusting away as yard art. The story in the last issue detailed the rescue, but what I didn't find out until later was that it was Lane and Isabella's Grandfather Herbert that was the previous owner! He's excited to see this truck come back to life.



New wood!

Since the last issue, the AA has been busy working on the farm. Lane put a new bed on it, and this summer, it served as his sweet corn selling truck, among other tasks. That's Mia, a 3-year-old 154 lb. English Lab keeping watch. Mia never turns down a ride in the truck! Lane built her stairs to get into the back, but when hauling corn, she rides up front.



Mia keeps the corn safe!



Lane, Rachel & Mia

It's not just all work and no play. The AA also gets to go to fun events! Lane drove in a recent parade for the Marion Springs Festival. It looks like the AA was plumb full, but that's the nice thing about having a large truck. In no particular order, riding in the truck was Lane, and his fiancée Rachel, cousins Stacie, Paige, Bryan, Sister Isabella, and friend Mr. Godfrey. They all were quite excited when they found out they won best of show! Check out that trophy!

It's good to see this old truck full of kids, dogs, and corn!



A truckful!



Lane and Bryan with the trophy



More happy festival goers!



Waving at the crowd!



Model A Youth Restoration Award—2022

Submitted by Bob Moore

Let me tell you about Brooke Rozman!

Brooke is 13, lives in Elkhorn, Wisconsin, and is the third generation Model A owner in her Model A family.

She, her parents, and her grandparents are members of the Wisconsin Chapter of the Model A Ford Club of America. (MAFCA)

Brooke writes: "I've been in the club since I was born. I like Model A's because we do fun things and events in them. My parents help run club events.... I like to help set up kids' events, help set up meetings and help the other kids at events."

Brooke has a 1928 Sedan which the previous owner transformed into a Pickup. Brooke and her father ran it well enough that she learned to drive around the property. If Brooks decides to keep the pickup, the engine will need rebuilding, she will need a complete new interior, not to mention the essential items of good tires, brakes, and window glass. However, Brooke does have her eye on a Model A Coupe with a rumble seat, so time will tell which car she choose to pursue!

With her dad's help, Brooke hopes to complete a Model A for herself by 2024, when she will turn 15, and can receive her temporary driver's license.

Brooke is one of 10 recipients of the 2022 Model A Youth Restoration Award (MAYRA). Each of the ten received financial support in the form of gift certificates from various Model A parts vendors. Brooke will use the certificates as she works on her Model A.

MAYRA makes awards every two years to the new generation of Model A restorers between the ages of 12 and under 22. The next awards will be in 2024. Previous recipients are not barred from applying more than once! Check out the MAYRA website at ModelARestorationAward.org.



This is a Model A Town Car. It was built for use by those who employed a chauffeur, but it never really became popular. Only a little over 1000 were made, and it is thought that only 19 still exist. This picture is from the 2012 MAFCA's Coloring Book, available at MAFCA.com

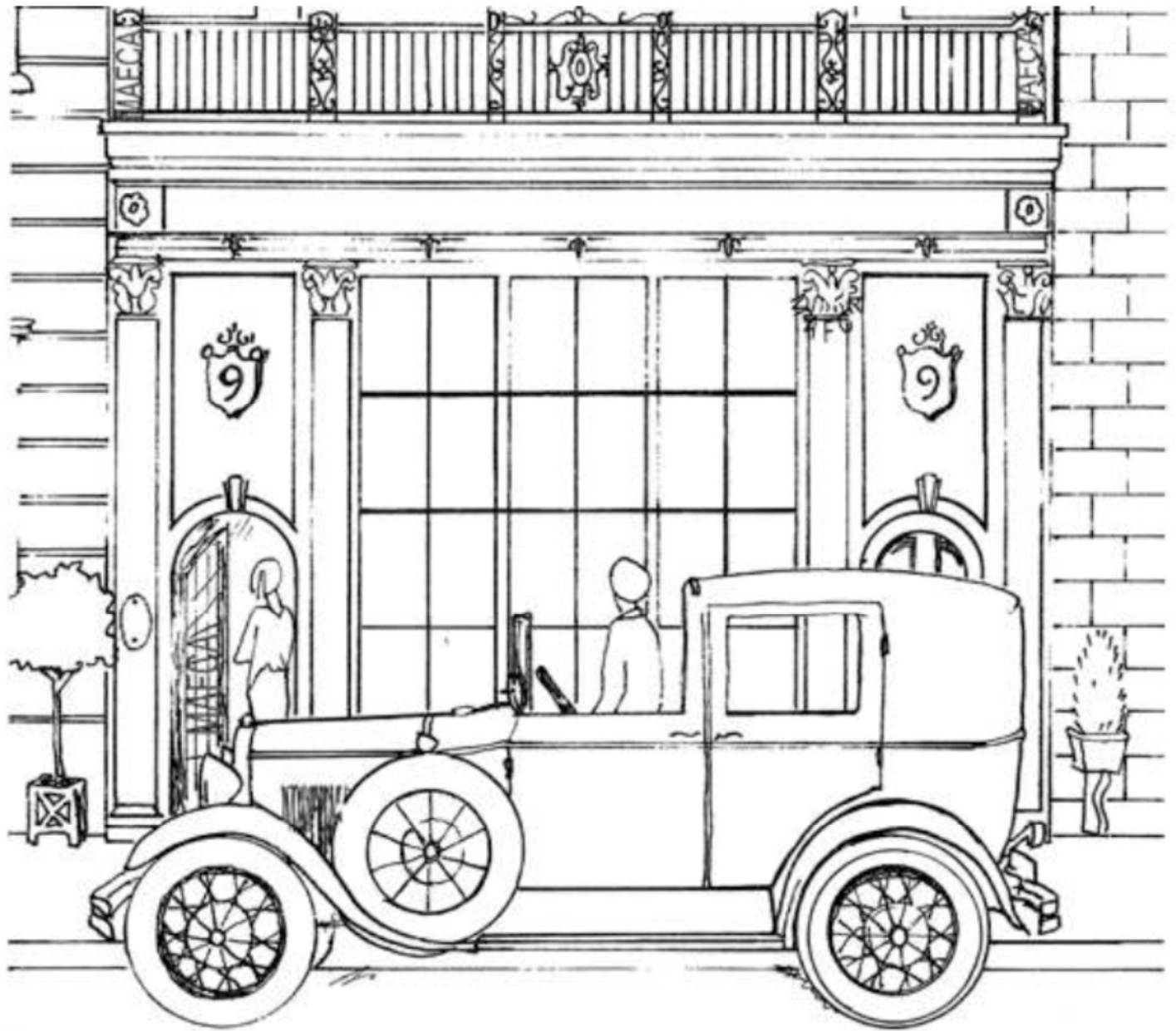



Rumble Seat

Sherry Wink

I'm happy to be telling your that The Old Lady is finally back on the road. She had

been garaged since last year after breaking down on a tour. Several times, we thought she was road-worthy as problems were found and fixed, but it finally came down to the fact that she needed a rebuild. After careful consideration, and discussion, I ended up buying an already rebuilt motor from a friend. I knew he had been trying to sell it for a while, and he made me a great deal!

My brother Richard took time from his work to get the motor switch done in August (summer is his busy time!) but there were still problems with the electrical system. She just didn't want to start! After some intensive work hours over several different periods of time, it turned out the main issue was that I had a 12v coil installed instead of the 6v I should have had! Once the new coil was installed, The Old Lady fired right up, and off we went!

My granddaughter and my nephew are both really enjoying having her back on the road! And so am I!

Hope you all are having as much fun Model A'ing this summer as we are! Send me pictures!



Quiz Time

Take a half sheet of paper. Number 1-10. Name at the top right corner. If you share this A-World with others in your family or friends, make sure you do not write on the newsletter pages. There are two ways to take this quiz: 1) Not looking back 2) Looking back as you take the quiz to find the answers. Try the "not looking" way first!

- 1) Who was Dad Sitzman's old schoolmate?
A) Larry B) Bud C) Leland
- 2) What were the twins looking forward to at the sawmill?
A) the work B) the pay C) the root beer
- 3) Brooke Bristol was the official " "?
A) driver B) waver C) niece
- 4) Walter and Oliver live in what city?
A) Clinton B) Chicago C) Charlotte
- 5) The water pump helps do what?
A) move water B) cool the motor block C) Both A & B
- 6) The Julian Gas Station museum is in what state?
A) Nebraska B) Kansas C) Iowa
- 7) What kind of beverage is Moxie?
A) Cider B) Juice C) Soda
- 8) What type of music was Rethan playing on the phonograph?
A) Blues B) Jazz C) Big Band
- 9) Brooke Rozman is what generation owner of her Model A?
A) 1st B) 2nd C) 3rd
- 10) Mia is what type of dog?
A) Poodle B) English Lab C) English Bulldog



Answers: 1) C, 2) C, 3) B, 4) C, 5) C, 6) A, 7) C, 8) B, 9) C, 10) B